

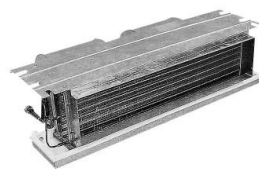

Cooling Only
Cooling Heating
50 Hz Models
MCD A18 DB
MCD A24 DB
MCD A30 DB
MCD A36 DB
MCD B42 DB
MCD B48 DB
MCD B60 DB



Reception

On arrival, inspect the unit before signing the delivery note. Specify any damage of the unit on the delivery note, and send a registered letter of protest to the last carrier of the goods within 72 hours of delivery. Notify the dealer at the same time.
The unit should be totally inspected within 7 days of delivery. If any concealed damage is discovered, send a registered letter of protest to the carrier within 7 days of delivery and notify the dealer.

About this Manual

Cautions appear at appropriate places in this Installation Manual. Your personal safety and the proper operation of this machine require that you follow them carefully.
The Trane Company assumes no liability for installations or servicing performed by unqualified personnel. All phases of the installation of this air conditioning system must conform to all national, provincial, state and local codes.

Warranty

Warranty is based on the general terms and conditions by country. The warranty is void if the equipment is modified or repaired without the written approval of The Trane Company, if the operating limits are exceeded or if the control system or the electrical wiring is modified.
Damage due to inappropriate installation, lack of knowledge or failure to comply with the manufacturer's instructions, is not covered by the warranty obligation. If the installation does not conform to the rules described in Installation Manual, it may entail cancellation of warranty and liabilities by The Trane Company.

Warning

Warnings are provided at appropriate places in this manual to indicate to installers, operators and service personnel of potentially hazardous situations which, if not avoided, COULD result in death or serious injury.

System Appearance

MCD 512-536 DB/D1
MCD 009-024 AA5

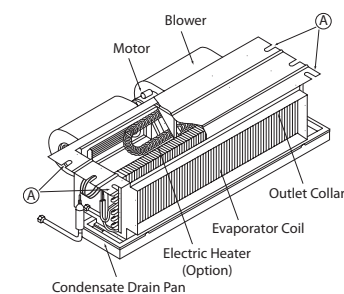

Note: Hanger recommendation for without return plenum model

MCD 048-060 DB/D1
MCD 030-042 EB5

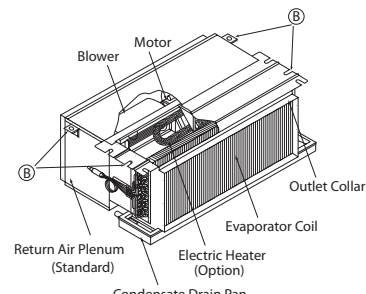

Note: Hanger recommendation for return plenum model

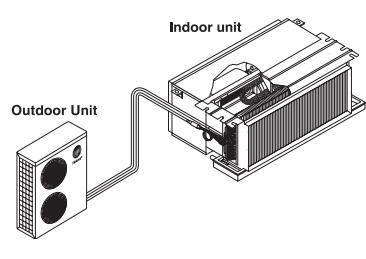
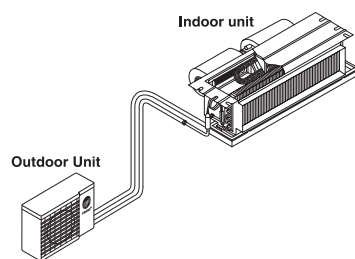

Units Installation

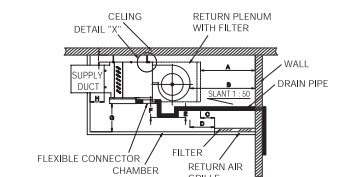

Figure 3 (SIDE VIEW)

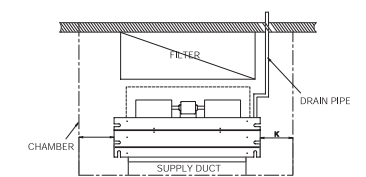

Figure 4 (TOP VIEW)

Table 1	A	B	C	D	E	F	G	H	I	J	K
DISTANCE (MM.)	Min. 750	Min. 800	100	150	50	200	Min. 200	Min. 100	Min. 50	Min. 300	Min. 300

NOTE: FOR DUCT LENGTH PLEASE SEE TABLE 2, 3, 4

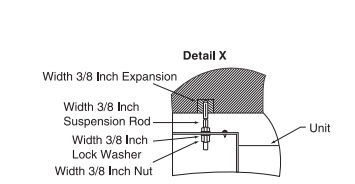

Figure 5

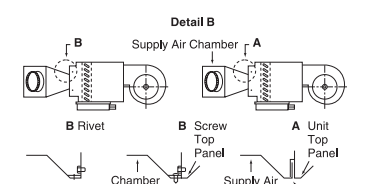

Figure 6

Installation Manual ILLUSION

Split System Concealed Type MCD Series 50 Hz

MS-SVN004-EN

General Information

Introduction

This Installation Manual is given as a guide to good practice in the installation by the installer of MCD mini-split system. Installation procedures should be performed in the sequence that they appear in this manual.
When installing the unit to operate properly and reliably, it must be installed in accordance with these instructions. Also, the services of a qualified service technician should be employed, through the maintenance contract with a reputable service company.
Read these installation instructions completely before installing the air conditioning system.

About the Unit

These MCD units are assembled, pressure tested, dehydrated, charged and run tested before shipment. The information contained in this manual applies to MCD units are designed to operate in cooling mode only and in cooling or heating modes.

Important

This document is customer property and is to remain with unit. Please place in service information pack upon completion of work. These instructions do not cover all variations in systems, nor do they provide for every possible contingency to be met in connection with installation.
Should further information be desired or should particular problems arise which are not covered sufficiently in this manual, the matter should be referred to your authorized Trane dealer.

Caution

Cautions are provided at appropriate places in this manual to indicate to installers, operators, and service personnel of potentially hazardous situations which, if not avoided, MAY result in minor or moderate injury or malfunction of the unit.

Location and Preparation of Units

Indoor Unit

- Select a convenient location that allows the air to reach every corner of the room and where it is easy to route the refrigerant tubing, wiring and drain to the outside.
- The ceiling construction should be strong enough to support the weight of the unit.
- The refrigerant tubing, drain piping and wiring conduit are connected through the wall.
- Refrigerant tubes between the indoor and the outdoor units and drain pipes should be as short as possible.
- If a refrigerant charge adjustment is necessary, follow the Installation Manual for the Outdoor Unit.

Outdoor Unit

See instructions for location and preparation of the unit in the Installation Manual for the Outdoor Unit.

Installation Method:

Indoor Unit

- After selecting the location to place the unit, follow these steps:
- Make a hole in the wall to route tubing and wiring through a locally purchased PVC pipe. The hole should slope downwards slightly, towards the outside (Figure 1).
 - Before cutting, check that no pipes or studs are directly behind the place to be cut.
 - Avoid areas where electrical wiring or conduits are located.
 - Hang the unit on a solid and level roof. Noise, vibration or leakage could occur on an unstable foundation (Figure 3, 4). For correct installation of duct work see (Figure 6).
 - Support the unit solidly.
 - To have access to electrical terminals, remove the right side junction box (Figure 2).
 - Note that refrigerant tubing, interconnecting wiring and drain hose should go through the wall. Shape these items so that they will easily fit through the wall.

Outdoor Unit

See the proper installation method provided in the Installation Manual for the Outdoor Unit.

Connection of Refrigerant Tubing

Proper installation procedure is recommended in the Installation Manual Package, usually provided together with the outdoor unit. It is advisable to read before installing.

The indoor unit refrigerant connections are located on the left hand side when facing the unit (Figure 7).

Connecting the Units with Flaring Procedure

- Cut the copper tube to the required length with a tube cutter. It is recommended to cut approx. 20-30 cm. longer than the tubing length.
- Remove burrs at the end of the copper tube with a tube reamer or file, as shown in Figure 8.
- When reaming, hold the tube end downward and be sure that no copper scraps fall into the tube (Figure 9).

Flare Specification

Copper diameter, In.(mm.)	H, (mm.)	D, (mm.)
1/4" (6.35)	1.0 - 2.0	8.6 - 9.7
3/8" (9.53)	1.0 - 3.0	12.4 - 13.9
1/2" (12.70)	1.0 - 2.0	15.7 - 16.1
5/8" (15.88)	1.0 - 3.0	19.0 - 20.3
3/4" (19.05)	1.0 - 3.0	22.4 - 22.7

A good flare should have the following characteristics:

- Inside surface is glossy and smooth.
- Edge is smooth.
- Tapered sides are of uniform length.

Cautions Before Connecting Tightly

- Be sure to apply a sealing cap or water-proof tape to prevent dust or water from getting into the tubes before they are used.
- Be sure to apply refrigerant lubricant to the matching surfaces of the flare and union before connecting them together.
- This is effective for reducing gas leaks (Figure 11).
- For proper connection, align the union tube and flare tube straight with each other, then screw in the flare nut lightly at first to obtain a smooth match (Figure 12).

Connecting the Unit with Brazing Procedure

- Cut the copper tube to the required length with a tube cutter. It is recommended to cut approx. 20-30 cm. longer than the tube length.
- Remove burrs at the end of the copper tube with a tube reamer (Figure 8).
- There are 2 ways to connect the copper tube
 - Use a coupling between the copper tube of Fan Coil Unit and the copper tube used for installation (Figure 13).
 - Expand the copper tube by using a swaging tool set as in Figure 14.
- To braze the copper tube, before brazing a copper tube to a solder coupling or a copper tube to an expanded tube, do not forget to keep them tight as shown in Figure 15.
- While welding copper tube. You should to Nitrogen flow in tube for protect soot occurred.

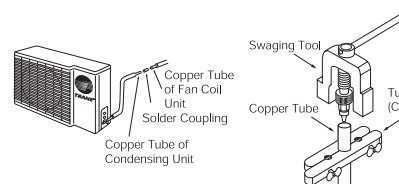

Figure 13

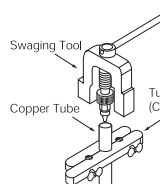

Figure 14

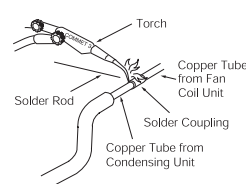
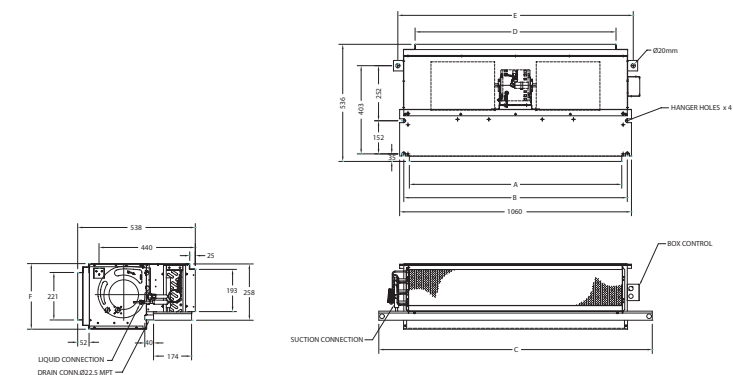

Figure 15

Condensate Drain Piping

- The drain hose should run straight down the wall to a level where the run off will not stain the wall.
- These should be no water traps. Avoid putting the end of the hose in water.
- To conveniently drain the system, the drain piping must slant downward, with a slope of at least 1:50 to prevent leakage.
- When the drain hose is placed in the room, insulate the hose with foam polyethylene to avoid damage to the ceiling or furniture.
- After completing installation of refrigerant lines, wiring and drain connections, bind the tubing, wiring and drain piping (check if local codes permit binding) into a bundle by using tape at 100 or 200 mm (4" to 8") intervals. Make sure the drain tube is at the bottom of the bundle (Figure 16).

Dimensional Data



All External Dimensions are in inch (mm)

Model	A	B	C	D	E	F	Refrig. Line Conn. Size	Number Of
MCD A18DB/A	58 (1497.2)	46 (1173.2)	49 (1247.5)	38 (965)	42 (1066.7)	17 (430)	3/8" (9.53)	2
MCD A24DB/A	58 (1497.2)	46 (1173.2)	49 (1247.5)	38 (965)	42 (1066.7)	17 (430)	3/8" (9.53)	2
MCD A30DB/A	58 (1497.2)	46 (1173.2)	49 (1247.5)	38 (965)	42 (1066.7)	17 (430)	3/8" (9.53)	2
MCD A36DB/A	58 (1497.2)	46 (1173.2)	49 (1247.5)	38 (965)	42 (1066.7)	17 (430)	3/8" (9.53)	2

Dimensional Data

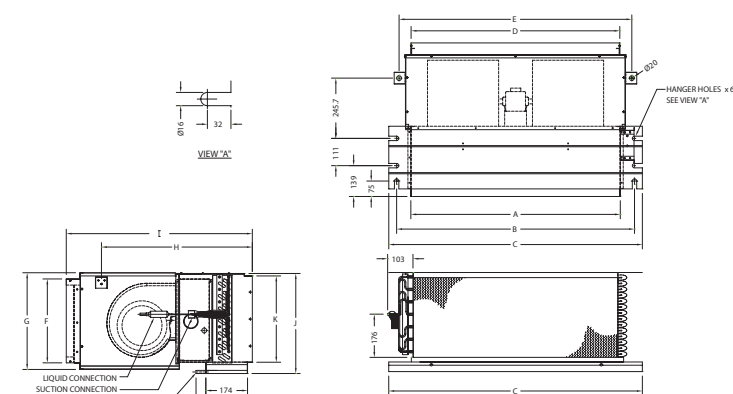

All External Dimensions are in inch (mm)

Model	A	B	C	D	E	F	G	H	I	J	K	Refrig. Line Conn. Size	Number Of
MCD 009-024AA5	47 (1194)	41 (1041.4)	41 (1041.4)	41 (1041.4)	41 (1041.4)	41 (1041.4)	41 (1041.4)	41 (1041.4)	41 (1041.4)	41 (1041.4)	41 (1041.4)	3/8" (9.53)	2
MCD 030-042EB5	47 (1194)	41 (1041.4)	41 (1041.4)	41 (1041.4)	41 (1041.4)	41 (1041.4)	41 (1041.4)	41 (1041.4)	41 (1041.4)	41 (1041.4)	41 (1041.4)	3/8" (9.53)	2
MCD 048-060DB/D1	47 (1194)	41 (1041.4)	41 (1041.4)	41 (1041.4)	41 (1041.4)	41 (1041.4)	41 (1041.4)	41 (1041.4)	41 (1041.4)	41 (1041.4)	41 (1041.4)	3/8" (9.53)	2
MCD 512-536DB/D1	47 (1194)	41 (1041.4)	41 (1041.4)	41 (1041.4)	41 (1041.4)	41 (1041.4)	41 (1041.4)	41 (1041.4)	41 (1041.4)	41 (1041.4)	41 (1041.4)	3/8" (9.53)	2

Electrical Installation

All wiring and grounding must comply with local electrical codes.

Wiring Important Safeguards:

- Check the unit nameplate for electrical rating. Be sure wiring is done according to local codes and wiring diagram.
- Use a separate power line with circuit breaker for each air conditioning unit.
- Connect electrical ground to all units.
- Wiring should not touch refrigerant tubing, compressor, motors or moving parts.
- The manufacturer will accept no responsibility for problems caused by unauthorized changes in the internal wiring.
- Connect the wiring firmly.

Indoor Unit

Remove the right side junction box (see previous instructions) to access the terminal base.

System Wiring Routing

- Pass the system wiring through the PVC pipe, referred to in the Section of Installation Method (both power and control lines) to interconnect indoor and outdoor units.
- Connect the wire terminals to the terminal base. See connection indication on system wiring diagram.
- Make sure all connections are tight.

Outdoor Unit

See the electrical installation instructions in the Installation Manual for the Outdoor Unit.

Wiring Diagram

CONCEALED FAN COIL UNITS COOLING ONLY

- MCD 009-012 AA5 (3 SPEEDS)
- MCD 018-024 AA5 (4 SPEEDS)
- MCD 030 EB5 (4 SPEEDS)
- MCD 036 EB5 (3 SPEEDS)
- MCD 512-536 DB/D1 (4 SPEEDS)
- MCD 048-060 DB/D1 (4 SPEEDS)
- MCD 042 EB5 (4 SPEEDS)

Remove HI-BR wire from TB-1 and replace with EXTRA HI-BLK wire when high speed/cfm is required in the field.

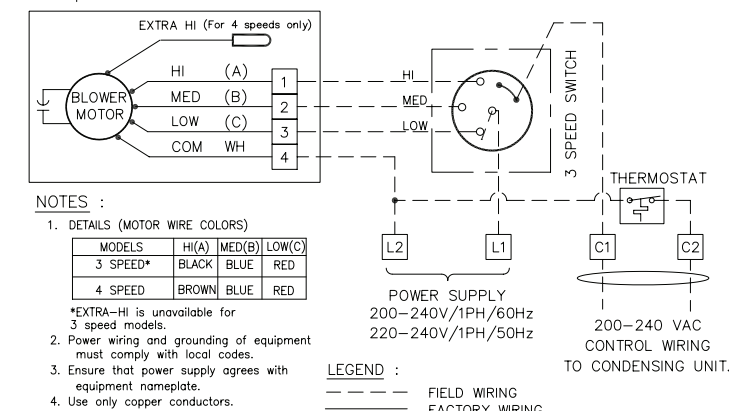

Wiring Diagram

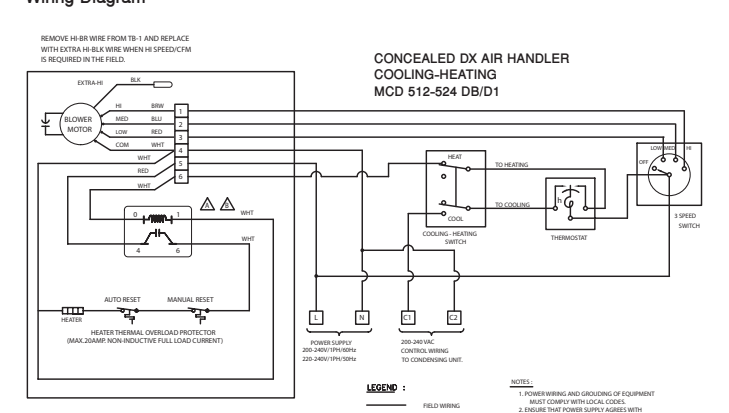

Wiring Diagram

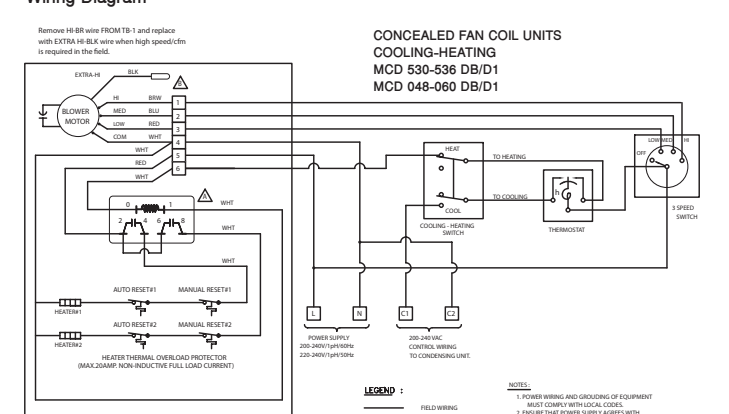

Maintenance

Regular Maintenance

Be sure to disconnect the power before inspection or maintenance air conditioner.

- Cleaning the air filter
 - Air flow is reduced and cooling efficiency impaired if the filter is clogged. Be sure to clean the filter every two weeks during the cooling season.

1.1 Remove air filters to side

- Slide air filter to left or right side.

1.2 Remove air filters to bottom

- Loose screws located under the filters at return air plenum set.
- Remove air filter frame and pull air filter down.

How to clean the air filter

- Wash away dust from the air filters with clean water or vacuum it with an electric vacuum cleaner.

Note: Once the air filter is washed, dry it completely before returning it to its original position.

After cleaning be sure to return it to its original position.

Cautions

- Do not wash the air filter in water that is over 40°C or it may shrink.
- Do not expose the air filter to fire.
- Do not expose the air filter to direct sunlight for a long time when the air is very dry.
- Clean the air filter more frequently.



For more information, contact your local district office

Literature Order Number: MS-SVN008-EN

Date: September 2013

Supersedes: September 2013

Stocking Location: Bangkok, Thailand

Trane has a policy of continuous product and product data improvement and reserves the right to change design and specifications without notice.