

Installer's Guide

Condensing Units

2TTB0512-536A1 & 2TTB0512-536AA

ALL phases of this installation must comply with NATIONAL, STATE AND LOCAL CODES

IMPORTANT — This Document is **customer property** and is to remain with this unit. Please return to service information pack upon completion of work.

These instructions do not cover all variations in systems nor provide for every possible contingency to be met in connection with installation. All phases of this installation must comply with NATIONAL, STATE AND LOCAL CODES. Should further information be desired or should particular problems arise which are not covered sufficiently for the purchaser's purposes, the matter should be referred to your installing dealer or local distributor.

A. GENERAL

The following instructions cover 2TTB05; Condensing Units.

NOTICE:

These outdoor units may be used with indoor units equipped with Thermostatic Expansion Valve or Accutron™ Flow Control Check Valve (F.C.C.V.) assembly for refrigerant flow control only.

Check for transportation damage after unit is uncrated. Report promptly, to the carrier, any damage found to the unit.

To determine the electrical power requirements of the unit, refer to the nameplate of the unit. The electrical power available must agree with that listed on the nameplate.

B. LOCATION & PREPARATION OF THE UNIT

1. When removing unit from the pallet, notice the tabs on the basepan. Remove tabs by cutting with a sharp tool as shown in Figure 2 (see page 2).
2. The unit should be set on a level support pad at least as large as the unit base pan, such as a concrete slab. If this is not the application used please refer to application bulletin SSC-APG002-EN.
3. The support pad must NOT be in direct contact with any structure. Unit must be positioned a minimum of 12" from any wall or surrounding shrubbery to insure adequate airflow. Clearance must be provided in front of control box (access panels) & any other side requiring service access to meet National Electrical Code. Also, the unit location must be far enough away from any structure to prevent excess roof run-off water from pouring directly on the unit. Do not locate unit(s) close to bedroom(s).
4. The top discharge area must be unrestricted for at least five (5) feet above the unit.

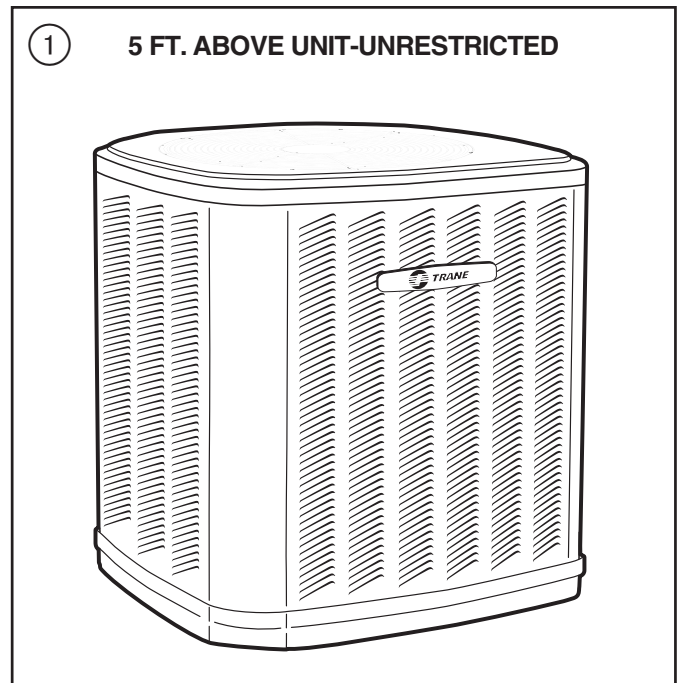

5. When the outdoor unit is mounted on a roof, be sure the roof will support the unit's weight. Properly selected isolation is recommended to prevent sound or vibration transmission to the building structure.
6. The maximum length of refrigerant lines from outdoor to indoor unit should NOT exceed sixty (60) feet.
7. If outdoor unit is mounted above the air handler, maximum lift should not exceed sixty (60) feet (suction line). If air handler is mounted above condensing unit, maximum lift should not exceed sixty (60) feet (liquid line).

NOTE:

Refer to "Refrigerant Piping Software" Pub. No. 32-3312-02.

8. Locate and install indoor coil or air handler in accordance with instruction included with that unit.

Installer's Guide

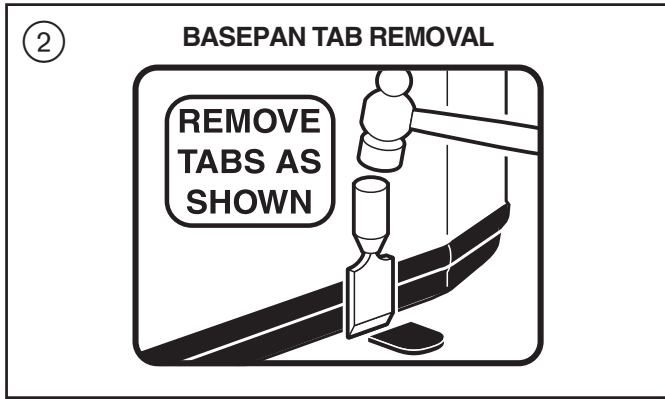

C. ACCUTRON™ FLOW CONTROL VALVE

If the indoor unit System Refrigerant Flow control is an Accutron™ orifice and check valve assembly, an orifice size change may be necessary. See Figure 3.

The outdoor model determines the required orifice size. Check the listed orifice size on nameplate of the selected outdoor model. If the indoor unit is factory shipped with a different orifice size, the orifice must be changed to obtain system rated performance.

IMPORTANT:

The outdoor unit is shipped with the proper size orifice and a stick-on orifice size label in an envelope attached to the outdoor unit. Outdoor unit nameplate will have correct orifice size specified as BAYFCCV---A for rated performance.

D. INSTALLING REFRIGERANT LINES

Condensing units have provisions for flare connections.

Pressure taps are provided on the service valves of outdoor unit for compressor suction and liquid pressures.

The indoor end of the recommended refrigerant line sets may be straight or with a 90 degree bend, depending upon situation requirements. This should be thoroughly checked out before ordering refrigerant line sets.

The gas line must always be insulated.

IMPORTANT:

The unit has a NITROGEN holding charge which will need to be evacuated before charging per local system application requirement.

Refrigerant charge adjustment is necessary. Use the Charging Charts in the outdoor unit Service Facts.

1. Determine the most practical way to run the lines.
2. Consider types of bends to be made and space limitations.

NOTE:

Large diameter tubing will be very difficult to rebend once it has been shaped.

3. Determine the best starting point for routing the refrigerant tubing- **INSIDE OR OUTSIDE THE STRUCTURE.**
4. Provide a pull-thru hole of sufficient size to allow both liquid and gas lines.
5. Be sure the tubing is of sufficient length.
6. Uncoil the tubing --- do not kink or dent.
7. Route the tubing making all required bends and properly secure the tubing before making connections.

8. To prevent a noise within the building structure due to vibration transmission from the refrigerant lines, the following precautions should be taken:
 - a. When the refrigerant lines have to be fastened to floor joists or other framing in a structure, use isolation type hangers.
 - b. Isolation hangers should also be used when refrigerant lines are run in stud spaces or enclosed ceilings.
 - c. Where the refrigerant lines run through a wall or sill, they should be insulated and isolated.
 - d. Isolate the lines from all ductwork.

E. SERVICE VALVE OPERATION

BRASS LIQUID AND GAS LINE SERVICE VALVES

The Brass Liquid and Gas Line Service Valves are factory shipped in the seated position to hold factory charge. The pressure tap service port (when depressed) opens only to the field side of the valve when the valve is in the seated position. The liquid line valve is **not** a back seating valve (see **WARNING** below).

⚠ WARNING

Extreme caution should be exercised when opening the Liquid Line Service Valve. Turn valve stem counterclockwise only until the stem contacts the rolled edge. (See Figure 4) No torque is required.

FLARE FITTINGS

1. Remove gas and liquid line flare nuts from service valves and discard copper caps.
2. Cut and fit tubing minimizing the use of sharp 90 degree bends, for a even flare it is recommended that a tube cutter be used. A hacksaw should not be used to cut the tubing.
3. Remove any burrs from the inside edge of copper tubes with a deburring tool or knife.
4. Place the flare nuts on copper tubes before flaring tube ends. See Figure 5.
5. Flare the tube ends using a rotating flaring tool or compression type. Tube flare cone and flare tool should be well lubricated with refrigeration oil while it is being formed.

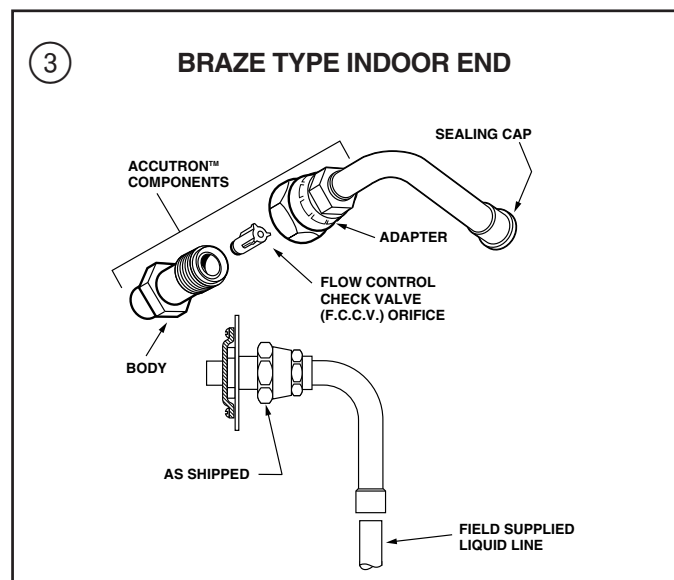

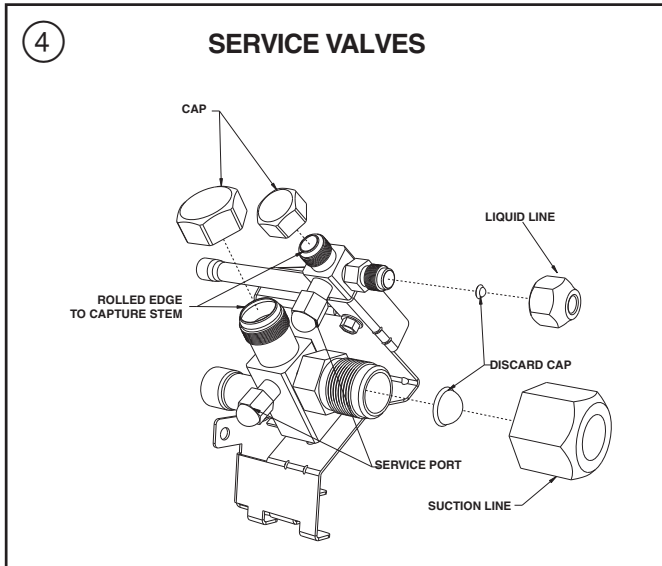

6. Prior to assembling the flares, check the mating surfaces for the following:

- Thinning of the flare tube material.
- Cracked or split tube.
- Scoring or longitudinal tool marks.
- Contamination.
- Surface roughness or deformation.

Note: If any of these conditions are observed, the part is defective and must be replaced.

7. The mating faces of the fitting should be joined squarely, with no lateral or longitudinal strain on the fitting.

8. The nut should be torqued per the values on the outline drawing (page 6).

9. When tightening the flare joints two wrenches must be used. The fitting must be securely supported by the stationary wrench.

10. Flared joints are not field repairable. If any damage is found, that portion must be cut from the tubing and the flare remade.

LEAK CHECK

IMPORTANT:

Replace pressure tap port valve core before attaching hoses for evacuation.

After the installing of refrigerant lines to both the outdoor and indoor unit is completed, the field connections must be checked for leaks. Pressurize through the service valve ports, the indoor unit and field refrigerant lines with dry nitrogen to 350-400 psi. Use soap bubbles or other leak-checking methods to see that all field joints are leak-free! If not, **release pressure**; then repair!

SYSTEM EVACUATION

NOTE:

Since the outdoor unit has a refrigerant charge, the gas and liquid line valves must remain closed.

- Upon completion of leak check, evacuate the refrigerant lines and indoor coil before opening the gas and liquid line valves.
- Attach appropriate hoses from manifold gauge to gas and liquid line pressure taps.

NOTE:

Unnecessary switching of hoses can be avoided and complete evacuation of all lines leading to sealed system can be accomplished with manifold center hose and connecting branch hose to a cylinder of HCFC-22 and vacuum pump.

- Attach center hose of manifold gauges to vacuum pump.
- Evacuate until the micron gauge reads no higher than 350 microns.
- Close off valve to vacuum pump and observe the micron gauge. If gauge pressure rises above 500 microns in one (1) minute, then evacuation is incomplete or system has a leak.
- If vacuum gauge does not rise above 500 microns in one (1) minute, the evacuation should be complete.
- With vacuum pump and micron gauge blanked off, open valve on HCFC-22 cylinder and charge refrigerant lines and indoor coil with vapor to tank pressure of HCFC-22 supply.

NOTE:

DO NOT VENT REFRIGERANT INTO THE ATMOSPHERE.

- Close valve on HCFC-22 supply cylinder. Close valves on manifold gauge set and remove refrigerant charging hoses from liquid and gas pressure tap ports.

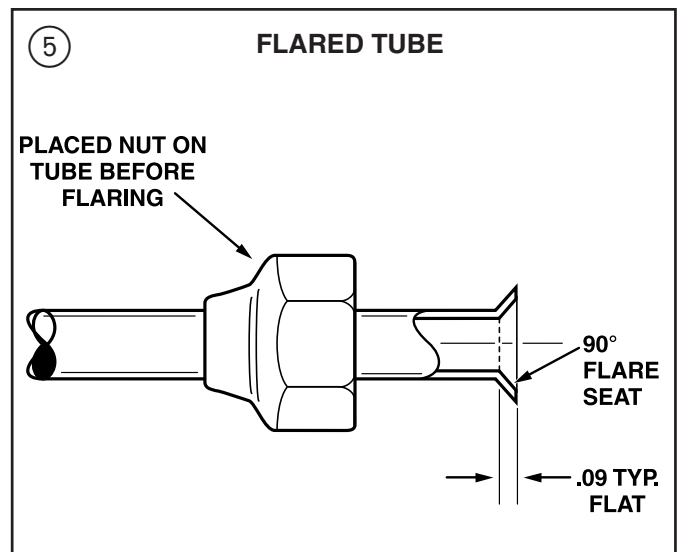

NOTE:

A 3/16" Allen wrench is required to open liquid line service valve. A 1/4" Open End or Adjustable wrench is required to open gas line valve. A 3/4" Open End wrench is required to take off the valve stem cap.

- The liquid line shut-off valve can now be opened. Remove shut-off valve cap. Fully insert hex wrench into the stem and backout counterclockwise until valve stem just touches rolled edge (approximately five [5] turns) observing **WARNING** statement on page 2. See Figure 4.
- Replace liquid service pressure tap port cap and valve stem cap. These caps **MUST BE REPLACED** to prevent leaks. Replace valve stem cap and pressure tap cap finger tight, then tighten an additional 1/6 turn.

Installer's Guide

- The gas valve can now be opened. For a ball type gas valve, open the gas valve by removing the shut-off valve cap and turning the valve stem 1/4 turn counterclockwise, using 1/4" Open End or Adjustable wrench. See Figure 5. For brass gas line service valve opening, follow 9 and 10 above. See Figure 4.
- The gas valve is now open for refrigerant flow. Replace valve stem cap to prevent leaks. Again, these caps **MUST BE REPLACED** to prevent leaks. Replace valve stem cap and pressure tap cap finger tight, then tighten an additional 1/6 turn. See Figure 5.

If refrigerant lines are longer than 15 feet and/or a different size than recommended, it will be necessary to adjust system refrigerant charge upon completion of installation. See unit Service Facts.

F. ELECTRICAL CONNECTIONS

⚠ WARNING

When installing or servicing this equipment, ALWAYS exercise basic safety precautions to avoid the possibility of electric shock.

- If factory leads are attached to the line side of the terminal block, please remove and discard before attaching the field power supply connection.
- Power wiring and grounding of equipment must comply with local codes.
- Power supply must agree with equipment nameplate.
- Install a separate disconnect switch at the outdoor unit.
- Ground the outdoor unit per local code requirements.
- Provide flexible electrical conduit whenever vibration transmission may create a noise problem within the structure.
- The use of color coded low voltage wire is recommended to simplify connections between the outdoor unit, the thermostat and the indoor unit.

Table 1 — NEC Class II Control Wiring

24 VOLTS	
WIRE SIZE	MAX. WIRE LENGTH
18 AWG	150 FT.
16 AWG	225 FT.
14 AWG	300 FT.

- Table 1 defines maximum **total** length of low voltage wiring from outdoor unit, to indoor unit, and to thermostat.
- Mount the indoor thermostat in accordance with instruction included with the thermostat. Wire per appropriate hook-up diagram (included in these instructions).

G. COMPRESSOR START UP

After all electrical wiring is complete, **SET THE THERMOSTAT SYSTEM SWITCH IN THE OFF POSITION SO COMPRESSOR WILL NOT RUN**, and apply power by closing the system main disconnect switch. This will activate the compressor sump heat (where used). Do not change the Thermostat System Switch until power has been applied for one (1) hour. Following this procedure will prevent potential compressor overload trip at the initial start-up.

H. OPERATIONAL AND CHECKOUT PROCEDURES

Final phases of this installation are the unit Operational and Checkout Procedures which are found in this instruction (see page 8). To obtain proper performance, all units must be operated and charge adjustments made in accordance with procedures found in the Service Facts.

I. ELECTRIC HEATERS

Electric heaters, if used, are to be installed in the air handling device according to the instructions accompanying the air handler and the heaters.

J. START CONTROL

Some models have quick start components which are factory installed. For models that do not have factory installed start components, provisions are made for a field installed start kit accessory. When adding an accessory, follow the instructions provided with the kit.

K. OUTDOOR THERMOSTAT

An outdoor thermostat TAYSTAT250B may be field installed. For data, see wiring diagram attached to unit and instruction sheet packaged with outdoor thermostat.

L. SEACOAST SHIELD

If installed within one mile of salt water, including seacoasts and inland waterways, models without factory supplied Seacoast Salt Shields require the addition of BAYSEAC001 (Seacoast Kit) at installation time. Please refer to Application Guide SS-APB006-EN: *Trane - Seacoast Applications and Seacoast Corrosion Protection Bulletin UN-SVB11A-EN*.

M. TROUBLESHOOTING

TROUBLESHOOTING CHART — WHAT TO CHECK

SYSTEM FAULTS	TROUBLESHOOTING CHART — WHAT TO CHECK																										
	HIGH VOLTAGE WIRING	POWER SUPPLY	BLW CONDUIT	COMP. IOL	START CAPACITOR	CONTROL PANEL	CONTROL PANEL WIRING	CONTROL TRANSFORMER	CONTROL PANEL	CONTROL PANEL	LOW VOLTAGE WIRING	STYLING	REFRIG. OIL LEVEL	REFRIG. OIL LEAKS	REFRIG. UNDERCHARGE	EXCESSIVE DISCHARGE	REFRIG. OVERCHARGE	RESTRICTED AIR FLOW	OIL IN REFRIG. CIRCUIT	TXV/STUCK OPEN	TXV/STUCK CLOSED	REF. CREDIT IN REFRIG. CIRCUIT	REF. SUCTION OVERHEAT	OIL FAN SPEED SWITCH			
Liquid Pressure Too High																	S	P							S	S	
Liquid Pressure Too Low																S	P							S	S	S	S
Suction Pressure Too High															S	P	P						S	P			
Suction Pressure Too Low															S									S	P	S	
Liquid Refrig. Floodback TXV System																							S	S			
Liquid Refrig. Floodback Capillary Tube System																	P					S	S	S	P		
I.D. Coil Frosting																P									P	S	
Compressor Runs Inadequate or No Cooling															S	P	P	S						S	P	S	
ELECTRICAL																											
Compressor & O.D. Fan Do Not Start	P	P							S	P	P	P															
Compressor Will Not Start But O.D. Fan Runs	P	S	P	P	P	P									S												
O.D. Fan Won't Start	P																										
Compressor Hums But Won't Start	P	P	P	P	P	S									S												
Compressor Cycles on IOL	P	S	P	P	P	S									P	S	P	S	S		S			S	S		
I.D. Blower Won't Start	P	S								S	P	P															

P - Primary Causes S - Secondary Causes

TYPICAL FIELD HOOK-UP DIAGRAM FOR 2TTB0524-536 WITH A 230V CONTACTOR COIL

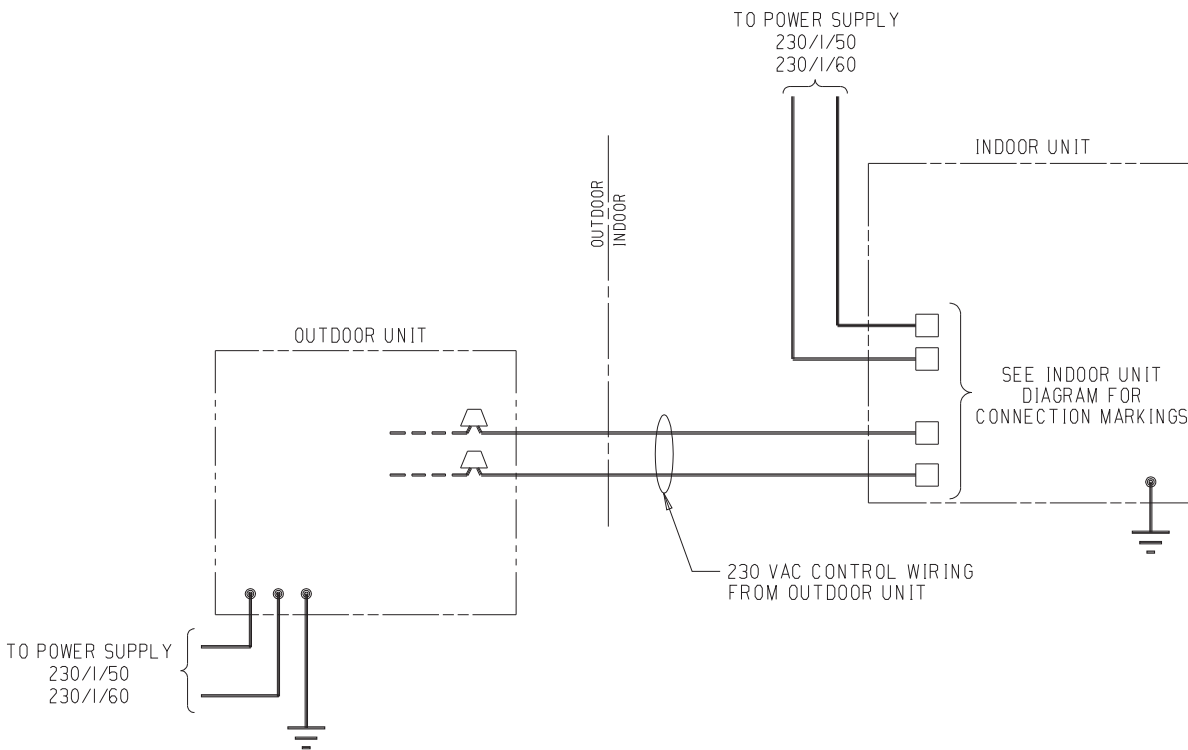

Notes:

1. Be sure power supply agrees with equipment nameplate.
2. Power wiring and grounding of equipment must comply with local codes.
3. Use copper conductors only.

LEGEND

- FACTORY WIRING
- FIELD WIRING

From Dwg. B151071 Rev.0

Installer's Guide

2TTB05 OUTLINE DRAWING

Note: All dimensions are in MM (Inches).

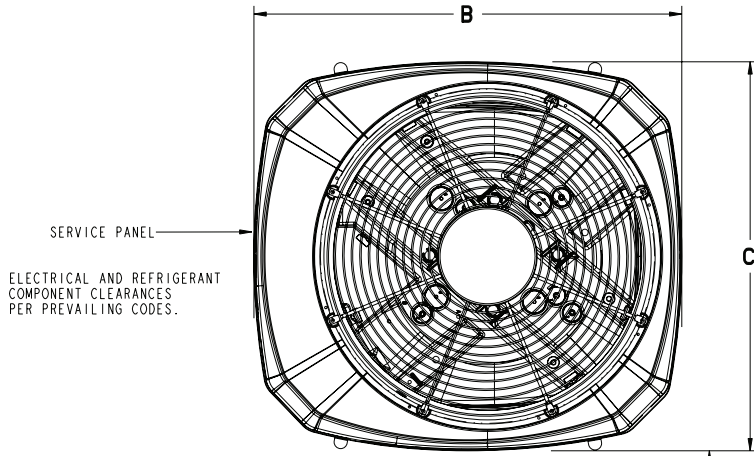

TOP DISCHARGE AREA SHOULD BE UNRESTRICTED FOR AT LEAST 1524 (5 FEET) ABOVE UNIT. UNIT SHOULD BE PLACED SO ROOF RUN-OFF WATER DOES NOT POUR DIRECTLY ON UNIT, AND SHOULD BE AT LEAST 305 (12") FROM WALL AND ALL SURROUNDING SHRUBBERY ON TWO SIDES. OTHER TWO SIDES UNRESTRICTED.

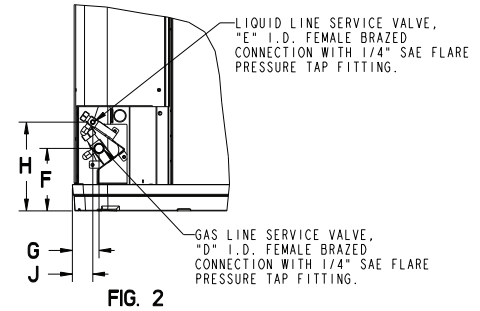
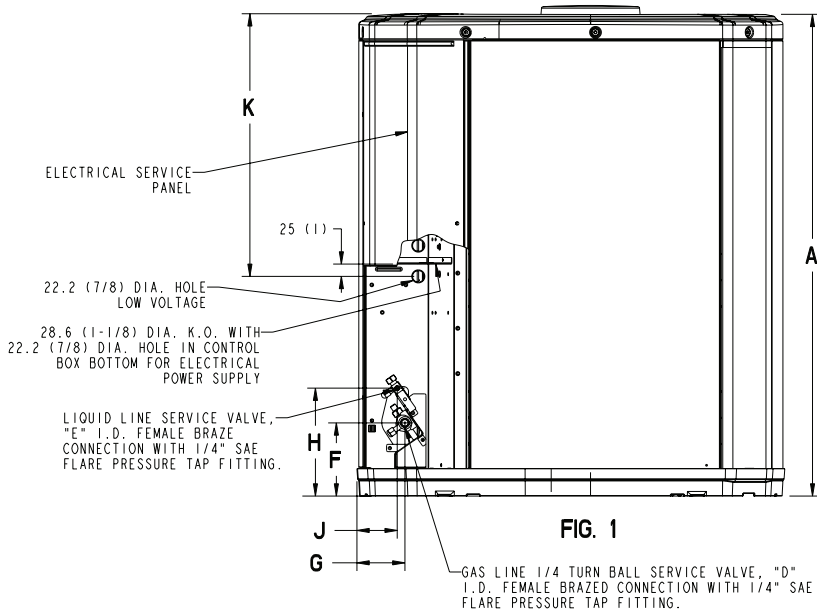

MODELS	BASE	FIG.	A	B	C	D	E	F	G	H	J	K	L	M
2TTB0512A1	1	2	648 (25-1/2)	502 (19-3/4)	476 (18-3/4)	5/8	1/4	149 (5-7/8)	16 (5/8)	90 (3-9/16)	19 (3/4)	460 (18-1/8)	7/8-14UNF 2A	7/16 20UNF-2A
2TTB0518A1	1	2	648 (25-1/2)	502 (19-3/4)	476 (18-3/4)	5/8	1/4	149 (5-7/8)	16 (5/8)	90 (3-9/16)	19 (3/4)	460 (18-1/8)	7/8-14UNF 2A	7/16 20UNF-2A
2TTB0524A1	1	2	648 (25-1/2)	502 (19-3/4)	476 (18-3/4)	3/4	5/16	149 (5-7/8)	16 (5/8)	90 (3-9/16)	19 (3/4)	460 (18-1/8)	1 1/16-14 UNF-2A	1/2-20 UNF- 2A
2TTB0530A1	2	1	561(25-5/8)	724 (28-1/2)	651 (25-5/8)	3/4	5/16	127 (5)	57 (2-1/4)	181 (7-1/8)	44 (1-3/4)	457 (18)	1 1/16-14 UNF-2A	1/2-20 UNF- 2A
2TTB0536A1	2	1	561(25-5/8)	724 (28-1/2)	651 (25-5/8)	3/4	5/16	127 (5)	57 (2-1/4)	181 (7-1/8)	44 (1-3/4)	457 (18)	1 1/16-14 UNF-2A	1/2-20 UNF- 2A
2TTB0512AA	1	2	648 (25-1/2)	502 (19-3/4)	476 (18-3/4)	5/8	1/4	149 (5-7/8)	16 (5/8)	90 (3-9/16)	19 (3/4)	460 (18-1/8)	7/8-14UNF 2A	7/16 20UNF-2A
2TTB0518AA	1	2	648 (25-1/2)	502 (19-3/4)	476 (18-3/4)	3/4	5/16	149 (5-7/8)	16 (5/8)	90 (3-9/16)	19 (3/4)	460 (18-1/8)	1 1/16-14 UNF-2A	1/2-20 UNF- 2A
2TTB024AA	2	1	561(25-5/8)	724 (28-1/2)	651 (25-5/8)	3/4	5/16	127 (5)	57 (2-1/4)	181 (7-1/8)	44 (1-3/4)	457 (18)	1 1/16-14 UNF-2A	1/2-20 UNF- 2A
2TTB0530AA	2	1	561(25-5/8)	724 (28-1/2)	651 (25-5/8)	3/4	5/16	127 (5)	57 (2-1/4)	181 (7-1/8)	44 (1-3/4)	457 (18)	1 1/16-14 UNF-2A	1/2-20 UNF- 2A
2TTB0536AA	2	1	730 (28-3/4)	724 (28-1/2)	651 (25-5/8)	3/4	5/16	137 (5-3/8)	65 (2-5/8)	210 (8-1/4)	57 (2-1/4)	457 (18)	1 1/16-14 UNF-2A	1/2-20 UNF- 2A

From Dwg. 21D153509 Rev. 1

MOUNTING HOLE LOCATION

Note: All dimensions are in MM (Inches).

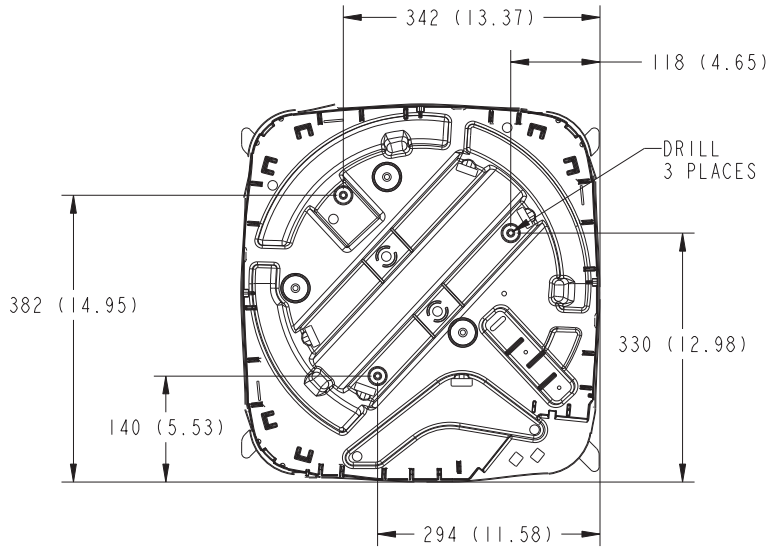

BASE 1

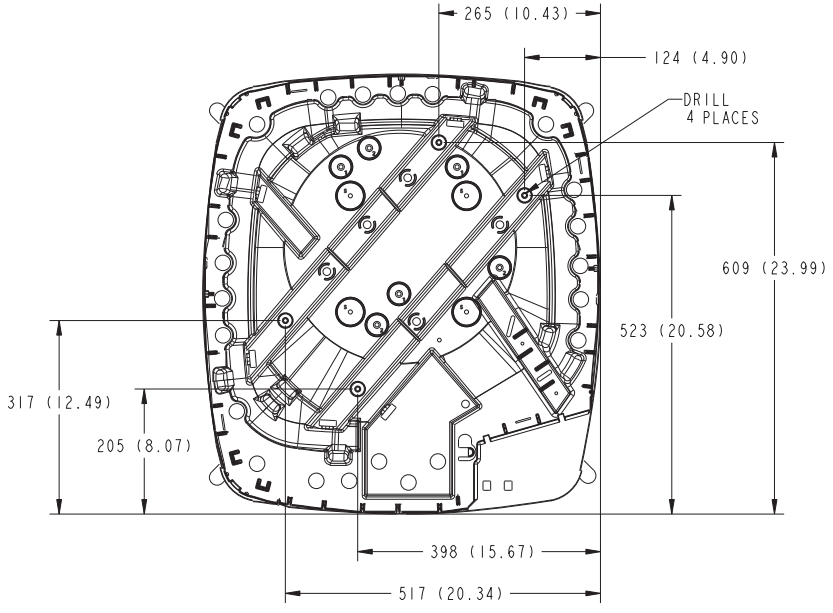

BASE 2

NOTE: For model base size, see table on page 6.

Installer's Guide

CHECKOUT PROCEDURE

After installation has been completed, it is recommended that the entire system be checked against the following list:

1. Refrigerant Line, Leak checked []
2. Suction Lines and Fittings properly insulated []
3. Have all Refrigerant Lines been secured and isolated properly? []
4. Have passages through masonry been sealed? If mortar is used, prevent mortar from coming into direct contact with copper tubing []
5. Verify tightness of all electrical connects []
6. Observe outdoor fan during on cycle for clearance and smooth operation []
7. Indoor coil drain line drains freely. Pour water into drain pan []
8. Supply registers and return grilles open and unobstructed []
9. Return air filter installed []
10. Thermostat thermometer is accurate. Check against a reliable thermometer. Adjust per instructions with thermostat []
11. Is correct speed tap being used? (Indoor blower motor) []
12. Operate complete system in each mode to insure safe operation. []

CHECKOUT PROCEDURE WITH MAIN POWER DISCONNECTS CLOSED (ON)

Step No.	TO CHECK	INDOOR THERMOSTAT SWITCH SETTING					COMPONENT OPERATION				
		Off	① Cool	① Heat	Fan Switch		Indoor Blower Runs	Outdoor Fan Runs	Compressor Runs	③ Comp. Sump Heater	Furnace Heat Comes On
					Auto	On					
1	Sump Heat	X			X					X	
2	Indoor Fan Operation	X				X	X			X	
3	Cooling Operation		X		X		X	X	X	X	
4	Checking Performance & Charge		X		X		X	X	X	X	
← USE CHARTS ATTACHED TO O.D. UNIT →											
5	Heating ②			X	X		X			X	X
6	Inform owner on how to operate system and what to expect of it. At the same time deliver Owner's Use and Care Booklet.										

- ① Also set thermostat dial to call for cooling or heating as necessary.
- ② Check only necessary if heating unit is used for indoor section and wiring has been disturbed during installation of cooling equipment.
- ③ When applicable.

